



## Features

- Nichia small size in high lumen LED upto 135lm/pc
- Low voltage-constant current 24 VDC system
- Wide viewing angle and helps eliminate wasted light
- Over molded design protects components from damage
- Pre-drilled holes and industrial-grade mounting tape
- Aluminum PCB in excellent heat dissipation
- Every 3LED cuttable
- 5-years warranty, more than 50,000hrs lifespan

## Application

- 8-17cm signage lighting box
- 8-17cm large channel letters

### BLUEVIEW ELEC-OPTIC TECH CO.,LTD

Tel: +86-28-8148 0011      Fax: +86-28-8148 1258  
Mail: sales@blueviewled.com      Web.: www.blueviewled.com  
Add: No.1000, Section 2, 2nd Konggang Road, Southwest  
Aviation Industrial Development Zone, Chengdu,Sichuan, China.  
Zip code: 610207

Specifications are subject to change without notice.  
©Blueview™ 2016 – All rights reserved. Made in China.

### Specifications

Part No.	BV-AL-3030-24V
Input Vol.	24VDC
Power/pc	1.5W
Lumen/pc	117lm
Led Type	SMD 3030
CRI	≥80
Max QTY/serie	12pcs
Dimension (LxWxD)	44x33x7.3mm

#### Color Available



### Dimension

Unit:mm[in]

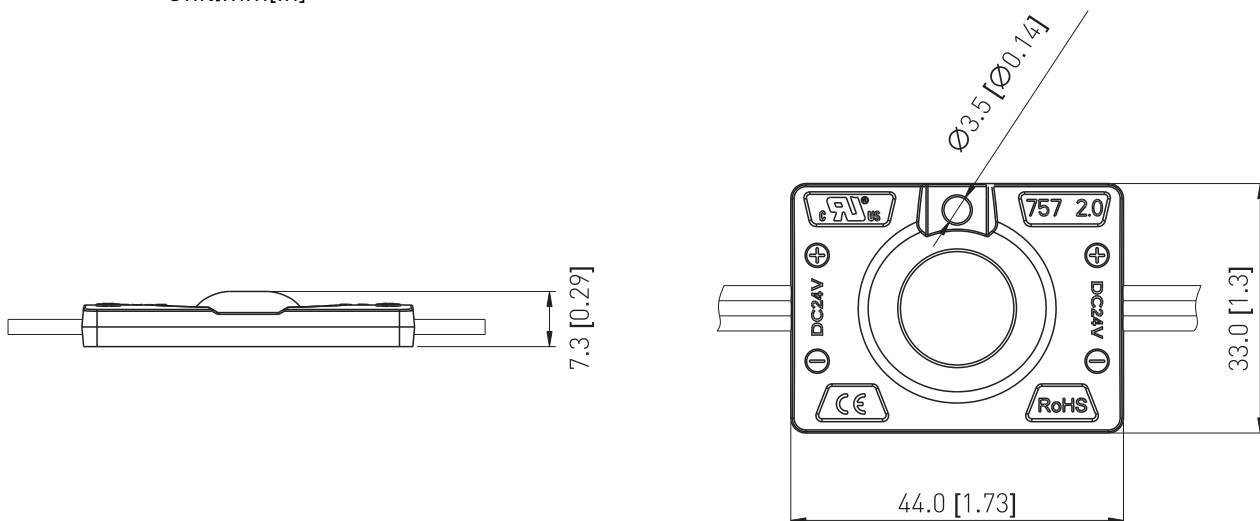

#### BLUEVIEW ELEC-OPTIC TECH CO.,LTD

Tel: +86-28-8148 0011      Fax: +86-28-8148 1258  
 Mail: sales@blueviewled.com      Web.: www.blueviewled.com  
 Add: No.1000, Section 2, 2nd Konggang Road, Southwest  
 Aviation Industrial Development Zone, Chengdu,Sichuan, China.  
 Zip code: 610207

Specifications are subject to change without notice.  
 ©Blueview™ 2016 – All rights reserved. Made in China.

### Luminous Intensity Distribution Diagram

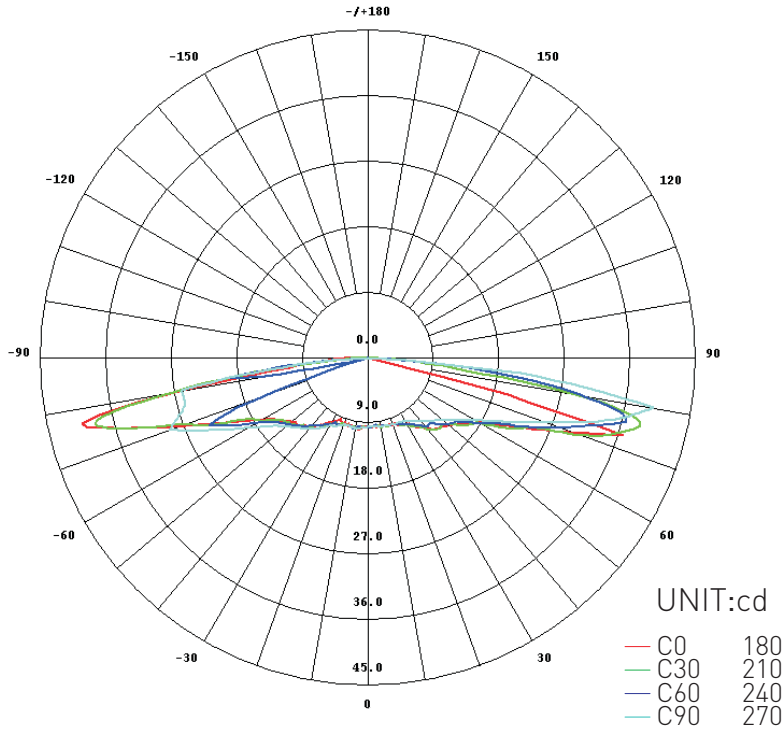

AVERAGE BEAM ANGLE(10%):169.4 DEG

### Installation

Thickness	Distance	Qty/ m <sup>2</sup>	Illumination
5cm	12cm	64pcs	4080-4510lux
5cm	14cm	49pcs	3830-4230lux
8cm	16cm	36pcs	2910-3360lux

#### BLUEVIEW ELEC-OPTIC TECH CO.,LTD

Tel: +86-28-8148 0011      Fax: +86-28-8148 1258  
 Mail: sales@blueviewled.com      Web.: www.blueviewled.com  
 Add: No.1000, Section 2, 2nd Konggang Road, Southwest  
 Aviation Industrial Development Zone, Chengdu,Sichuan, China.  
 Zip code: 610207

Specifications are subject to change without notice.  
 ©Blueview™ 2016 – All rights reserved. Made in China.

### Package

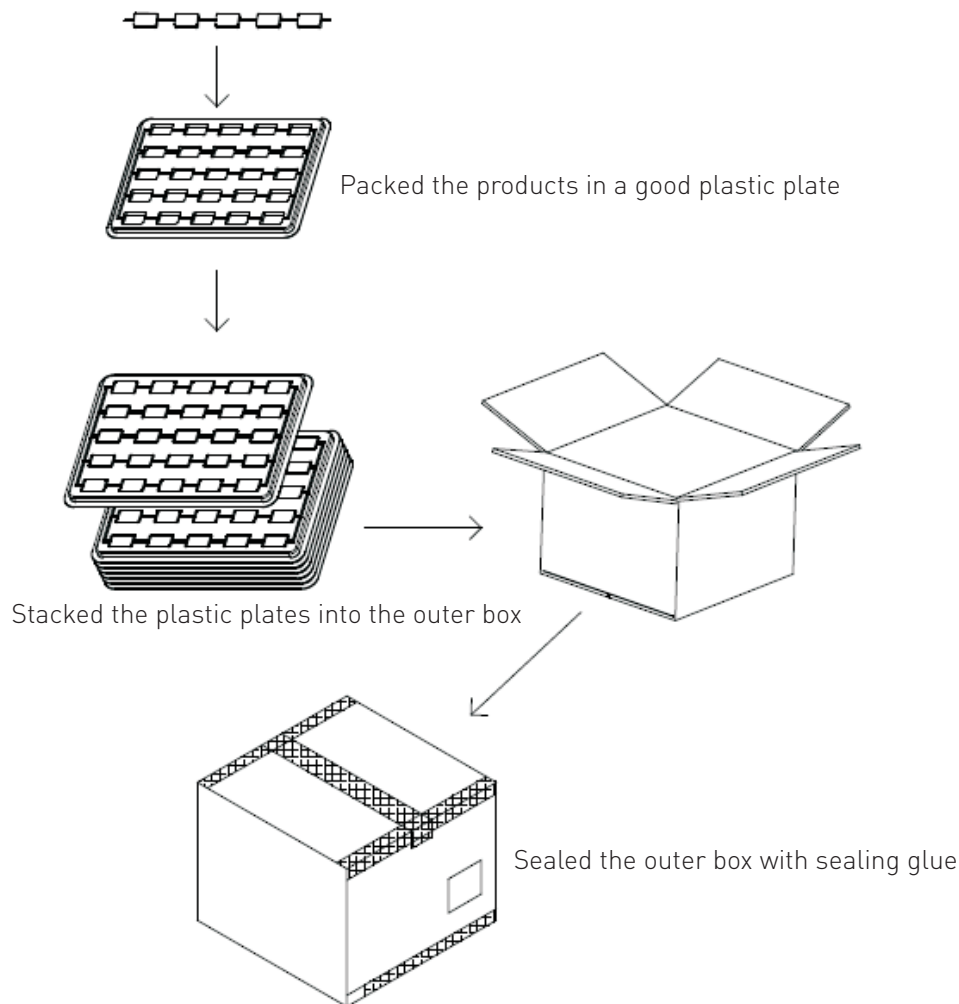

Part No	Size(mm)	Total Amount (Pcs/CTN)	Net Weight (kg)	Gross (kg)
BV-AL-3030-24V	44*33	720	12. 3(1±10%)	15. 7(1±10%)

1. Use transparent plastic plate loading, using medium box packaging
2. Outside box size: 550\*400\*340mm
3. 12pcs/string in one series connection , each 2 stings are loaded in one plastic tray, 30 blister tray loading 1 outer box.
4. The number and weight of the package only for the graphic packaging, when for other packaging methods when the number and weight of packaging will be different, specific to the kind prevail

#### BLUEVIEW ELEC-OPTIC TECH CO.,LTD

Tel: +86-28-8148 0011      Fax: +86-28-8148 1258  
 Mail: sales@blueviewled.com      Web.: www.blueviewled.com  
 Add: No.1000, Section 2, 2nd Konggang Road, Southwest  
 Aviation Industrial Development Zone, Chengdu,Sichuan, China.  
 Zip code: 610207

Specifications are subject to change without notice.  
 ©Blueview™ 2016 – All rights reserved. Made in China.