



Features

- High lumen~194lm per piece
- Low voltage-constant voltage 12 VDC system
- Wide viewing angle and helps eliminate wasted light
- Over molded design protects components from damage
- Pre-drilled holes and 3M mounting tape
- Contains no lead, mercury or glass

Application

- 8-15mm signage lighting box
- 8-15mm large channel letters

BLUEVIEW ELEC-OPTIC TECH CO.,LTD

Tel: +86-28-8148 0011 Fax: +86-28-8148 1258
Mail: sales@blueviewled.com Web.: www.blueviewled.com
Add: No.1000, Section 2, 2nd Konggang Road, Southwest
Aviation Industrial Development Zone, Chengdu,Sichuan, China.
Zip code: 610207

Specifications are subject to change without notice.
© Blueview™ 2016 – All rights reserved. Made in China.

Specifications

| | |
|--------------------------|-------------|
| Part No. | BV-ST13-2W |
| Input Vol. | 12VDC |
| Power/pc | 2.1W |
| Lumen/pc | 189-194lm |
| Led Type | SMD 3030 |
| CRI | ≥80 |
| Max QTY/serie | 20pcs |
| Dimension (LxWxD) | 52x35x7.3mm |
| Color Available | 6500K,8000K |

Product Drawing

Unit:mm[in]

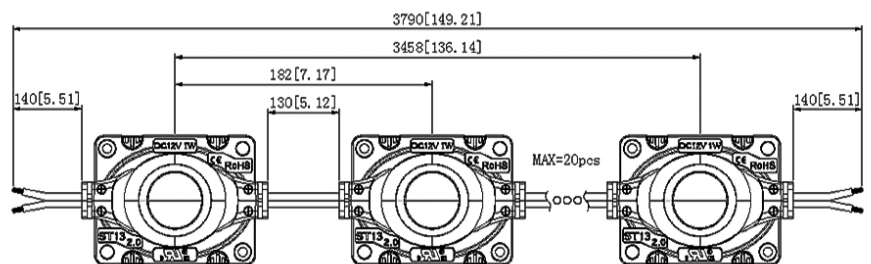
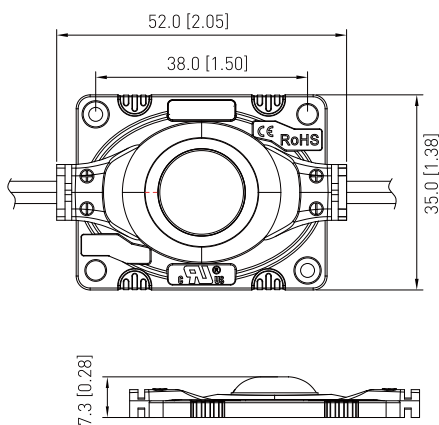

BV-ST13-2W

BLUEVIEW ELEC-OPTIC TECH CO.,LTD

Tel: +86-28-8148 0011 Fax: +86-28-8148 1258
 Mail: sales@blueviewled.com Web.: www.blueviewled.com
 Add: No.1000, Section 2, 2nd Konggang Road, Southwest
 Aviation Industrial Development Zone, Chengdu,Sichuan, China.
 Zip code: 610207

Specifications are subject to change without notice.
 © Blueview™ 2016 – All rights reserved. Made in China.

Installation //

| Thickness | Distance (x,y) | Qty/ m ² | Illumination |
|-----------|----------------|---------------------|--------------|
| 10cm | 12x12cm | 64pcs | 3820-4470lux |
| 15cm | 12x12cm | 64pcs | 2380-2940lux |
| 18cm | 12x12cm | 64pcs | 2120-2630lux |

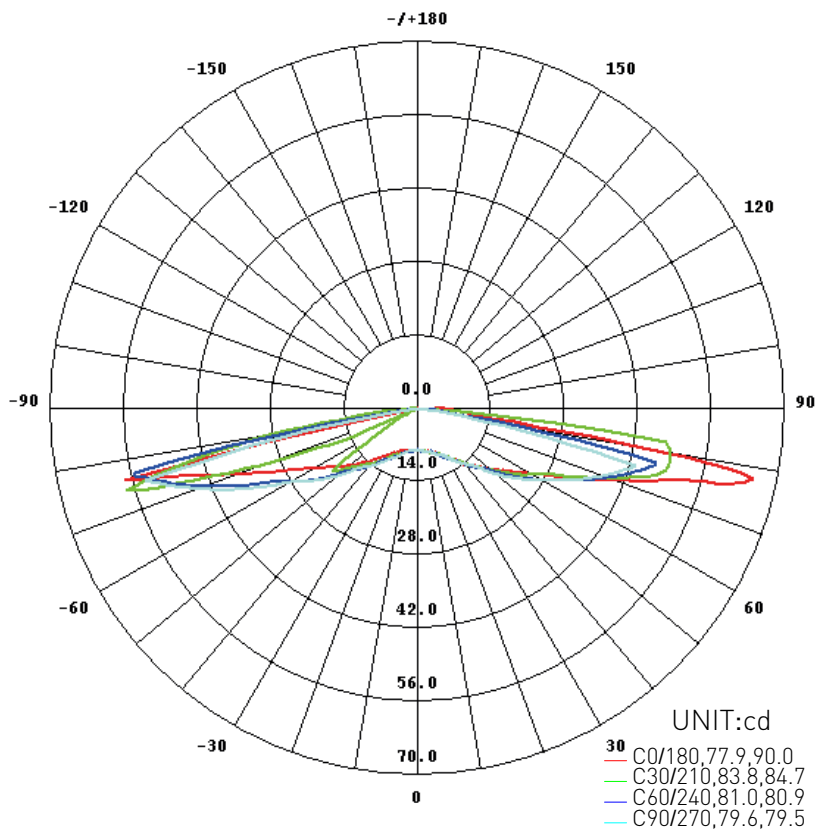
Luminous Intensity Distribution Diagram //

AVERAGE BEAM ANGLE(50%):164.4 DEG

BLUEVIEW ELEC-OPTIC TECH CO.,LTD

Tel: +86-28-8148 0011 Fax: +86-28-8148 1258
 Mail: sales@blueviewled.com Web.: www.blueviewled.com
 Add: No.1000, Section 2, 2nd Konggang Road, Southwest
 Aviation Industrial Development Zone, Chengdu,Sichuan, China.
 Zip code: 610207

Specifications are subject to change without notice.
 ©Blueview™ 2016 – All rights reserved. Made in China.

Package

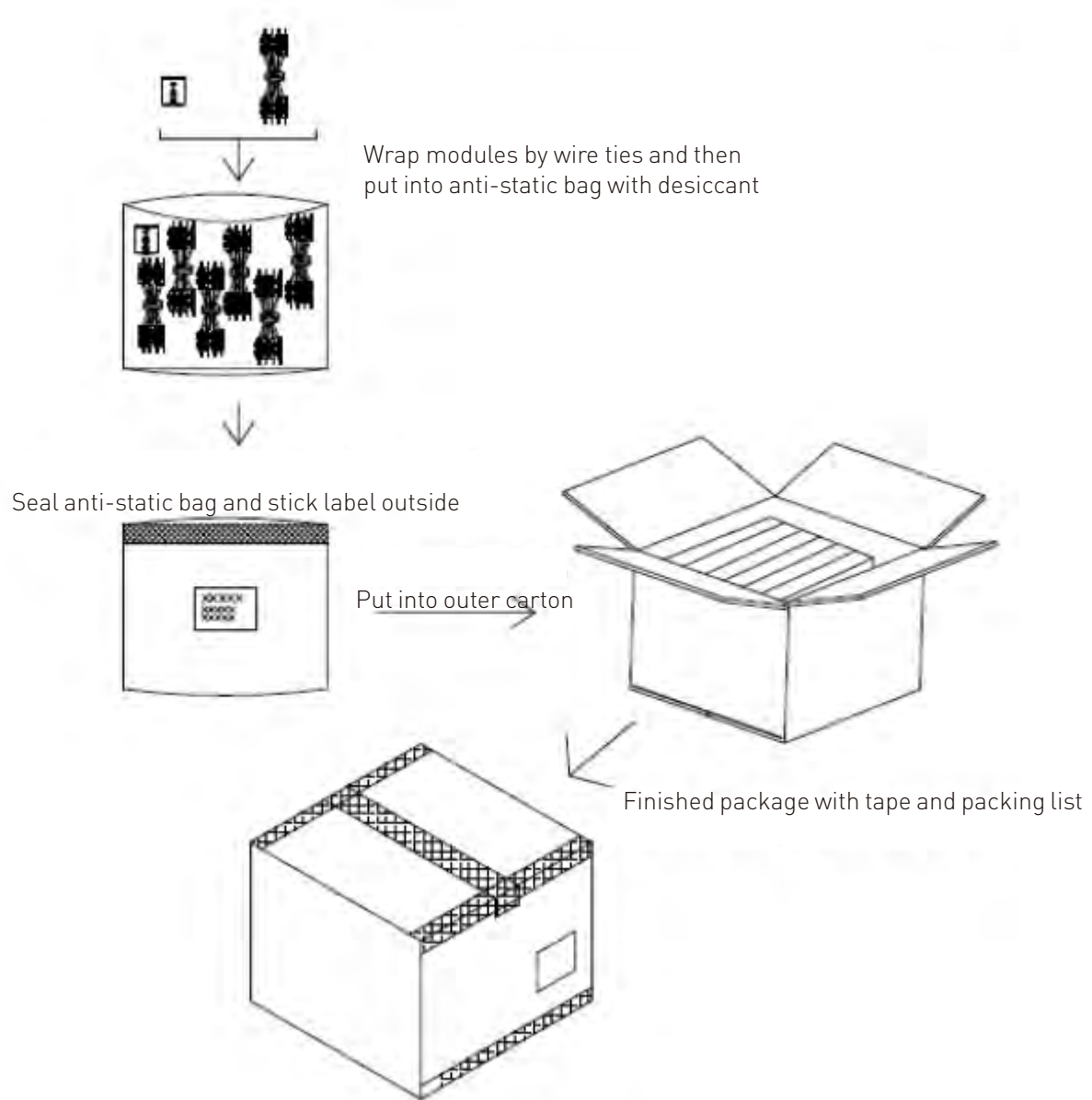

1. Outer carton dimension:570*375*285
2. 20pcs for one strings,4 strings(80pcs) in one anti-static bag
3. 20pcs of bags for one carton,1600pcs module for one carton
4. Net Weight per carton(NW):23.4(1±10%)kg
5. Gross Weight per carton(GW):24.7(1±10%)kg

BLUEVIEW ELEC-OPTIC TECH CO.,LTD

Tel: +86-28-8148 0011 Fax: +86-28-8148 1258
 Mail: sales@blueviewled.com Web.: www.blueviewled.com
 Add: No.1000, Section 2, 2nd Konggang Road, Southwest
 Aviation Industrial Development Zone, Chengdu,Sichuan, China.
 Zip code: 610207

Specifications are subject to change without notice.
 ©Blueview™ 2016 – All rights reserved. Made in China.